

Attachment E

**Inspection Report
48-50 Stanley Street, Darlinghurst**



Figure 1: 48-50 Stanley Street, Darlinghurst viewed from the south-west

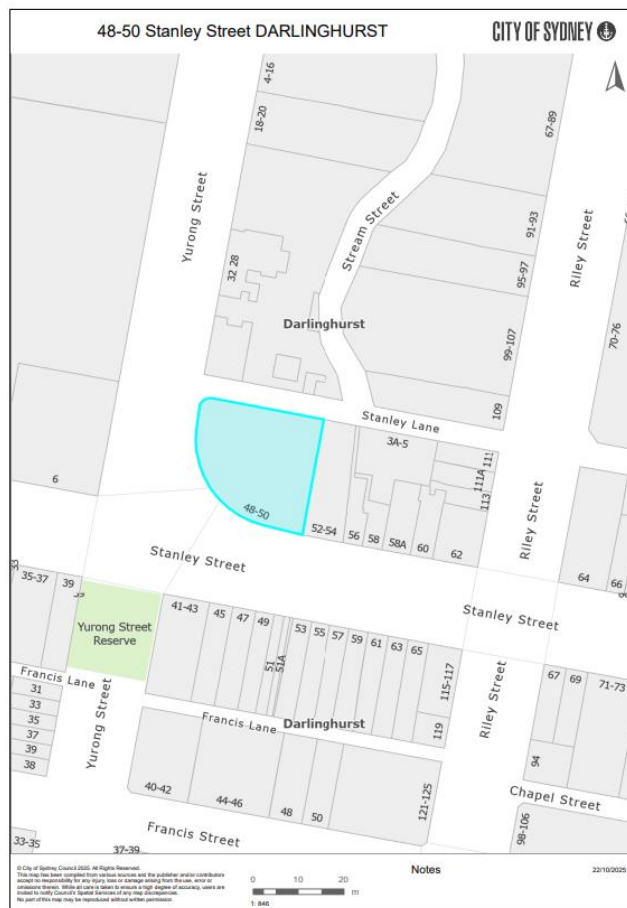

Figure 2: Location map of 48-50 Stanley Street, Darlinghurst

Council Investigation Officer Inspection and Recommendation Report; Clause 17(2) Part 8 of Schedule 5 of the Environmental Planning and Assessment Act 1979 (the Act)

Officer: Ashley Host

Date: 22 October 2025

Premises: 48-50 Stanley Street, Darlinghurst

Executive Summary

1. The City of Sydney (the City) received correspondence from the Commissioner of Fire and Rescue NSW (FRNSW) in relation to the subject premises dated 29 September 2025 with respect to matters of fire safety.
2. The premises consists of a 3 storey building used for commercial offices.
3. The City inspected the premises on 28 October 2025, accompanied by the building manager. This inspection found that fire safety was adequately provided.

Chronology

Date	Event
21 August 2025	As part of its investigation into the premises, FRNSW issued a Notice of Intention to serve a Fire Safety Order. This notice directed the property owners to carry out specified maintenance on the existing fire safety systems.
29 September 2025	FRNSW correspondence received.
28 October 2025	The City inspected the premises, which confirmed the issues raised by FRNSW had been rectified. No additional fire safety deficiencies were identified during the inspection.

Fire and Rescue NSW Report

4. Fire and Rescue NSW conducted an inspection of the subject premises on 3 July 2024.

Issues

5. The report from Fire and Rescue NSW detailed issues as shown in the table below.

Ref.	Issue	City response
Essential Fire Safety Measures		
Automatic Fire Suppression System		
1	The sprinkler booster connection is not readily accessible as it is obstructed by a timber surround.	The City's inspection on 28 October 2025 identified that the sprinkler booster had been rectified and was readily accessible with no obstructions, addressing this issue.
Fire Hydrant System		
2	The door to the hydrant booster connection could not be opened due to a problem with the lock.	The City's inspection on 28 October 2025 identified the hydrant booster door was able to be opened as required, addressing this issue.
Fire Hose Reels		
3	Multiple hose reels were not correctly wound and detached from the hose guide and nozzle interlocking device.	The City's inspection on 28 October 2025 identified all fire hose reels were correctly wound and attached to the hose guide and nozzle locking device, addressing this issue.
4	Data and telephone cabling was found stored in the fire hose reel cabinet on level 2.	The City's inspection on 28 October 2025 found no data cabling stored within the fire hose reel cabinet on level 2, addressing this issue.

6. FRNSW have recommended that the City inspect the subject premises and appropriately address noted (and other) deficiencies identified within their report..

Council Investigation Officer Recommendations

7. As a result of site inspections undertaken by the Council investigation officer it has been confirmed that the above recommendations of FRNSW have been complied with.
8. It is recommended that the Commissioner of FRNSW be informed of the City's decision.

OFFICIAL



File Ref. No: FRN25/1905 - BFS25/4178 - 8000043403
TRIM Ref. No: D25/116335
Contact: Station Officer Alex Cross

29 September 2025

General Manager
City of Sydney
GPO Box 1591
SYDNEY NSW 2001

Email: council@cityofsydney.nsw.gov.au

Attention: Manager Compliance/Fire Safety

Dear Sir / Madam

**RE: INSPECTION REPORT
48 – 50 STANLEY STREET
DARLINGHURST (“the premises”)**

Fire and Rescue NSW (FRNSW) received correspondence on concerning the adequacy of the provision for fire safety in or in connection with ‘the premises’.

The correspondence stated that:

There has been an alarm going off in the fire control panel for over a month which means that if there were an actual fire part of the system is non-responsive. The alarm is only quiet but painful after long periods.

Pursuant to the provisions of Section 9.32(1) of the *Environmental Planning and Assessment Act 1979* (EP&A Act), Authorised Fire Officers from the Fire Safety Compliance Unit of Fire and Rescue NSW (FRNSW) inspected ‘the premises’ on 3 July 2025. On behalf of the Commissioner of FRNSW, the comments in this report are provided under Section 9.32(4).

The items listed in the comments of this report are based on the following limitations:

- A general overview of the building was obtained without using the development consent conditions or approved floor plans as a reference.
- Details of the Provisions for Fire Safety and Fire Fighting Equipment are limited to a visual inspection of the parts in the building accessed and the fire safety measures observed at the time.

Fire and Rescue NSW
Community Safety Directorate
Fire Safety Compliance Unit

ABN 12 583 473 110
1 Amarina Ave
Greenacre NSW 2190

www.fire.nsw.gov.au
T (02) 9742 7434
F (02) 9742 7483

www.fire.nsw.gov.au

Page 1 of 10

OFFICIAL

COMMENTS

The following items were identified during the inspection:

Provision for Fire Safety

Automatic Fire Suppression (Sprinklers)

1. The Sprinkler Booster connection on Stanley Lane is not readily accessible as the booster connections are obstructed by a timber surround contrary to Clause 4.4.3 of Australian Standard (AS) 2118.1-1995.

Fire Hydrant System

2. The door of the Fire Brigade Hydrant Booster assembly on Yurong Street was not able to be opened due to a problem with the lock contrary to the requirements of Clause 7.3 of (AS) 2419.1-2005.

Fire Hose Reels (FHR)

3. Multiple FHR's throughout the premises were incorrectly wound and detached from the hose guide and nozzle interlocking device which may prevent occupants from being able to freely run out the FHR contrary to the requirements of Clause 12 (AS) 2441-2005.
4. Data and telephone cabling was found stored in the FHR cabinet on Level 2 which may interfere with use of the FHR contrary to Clause 10.4.4 of (AS) 2441-2005.

FRNSW believes that there are inadequate provisions for fire safety within the building.

NOTICE OF INTENTION TO SERVE AN ORDER

FRNSW issued a Notice of Intention to Serve an Order (1) dated 21 August 2025 (copy attached) under the provisions of Section 9.34 of the *Environmental Planning and Assessment Act 1979* (EP&A Act).

REPRESENTATIONS & INSPECTION

Written representations were received concerning the proposed **Order 1** under Schedule 5, Part 6, Section 8 of the EP&A Act, and after receiving the representations, an inspection was conducted on 22 September 2025 under Section 9.32 of the EP&A Act.

Upon hearing and considering the representation and subsequent inspection, FRNSW has decided not to give an Order under Schedule 5, Part 7, Section 15 of the EP&A Act.

OFFICIAL

The items listed in the comments of this report are based on the following limitations:

- A general overview of the building was obtained without using the development consent conditions or approved floor plans as a reference.
- Details of the Provisions for Fire Safety and Fire Fighting Equipment are limited to a visual inspection of the parts in the building accessed and the fire safety measures observed at the time.

Please do not hesitate to contact Station Officer Alex Cross of FRNSW's Fire Safety Compliance Unit at FireSafety@fire.nsw.gov.au or call (02) 9742 7434 if there are any questions or concerns about the above matters. Please refer to file reference FRN25/1905 - BFS25/4178 - 8000043403 regarding any correspondence concerning this matter.

Yours faithfully



Paul Scott
Team Leader
Fire Safety Compliance Unit

Attachments [Appendix 1 – Notice of Intention to Issue an Order - 5 pages]

OFFICIAL

Appendix 1 – Notice of Intention to Issue an Order



OFFICIAL

File Ref. No: FRN25/1905 - BFS25/4178 - 8000043403
TRIM Ref. No: D2025/095222
Contact: Inspector Paul Scott

21 August 2025

THE OWNERS - STRATA PLAN NO. 77891
48-50 Stanley Street
DARLINGHURST NSW 2010

Dear Owners of Strata No. 77891

**Re: NOTICE OF INTENTION
PROPOSED FIRE SAFETY ORDER – ORDER NO.1
48-50 STANLEY STREET DARLINGHURST("the premises")**

Authorised Fire Officers of the Fire Safety Compliance Unit of Fire and Rescue NSW (FRNSW) inspected "the premises" and identified fire safety concerns on Thursday, 3 July 2025. FRNSW gives you a **Notice of Intention to give a Fire Safety Order – Order No.1 ('Notice')** because of the concerns. This 'Notice' is issued under Section 9.34 of the *Environmental Planning and Assessment Act, 1979* (EP&A Act) and Schedule 5, Part 6, Section 8 (corporation) of the EP&A Act.

A copy of the **Proposed Fire Safety Order – Order No.1 ('Proposed Order')** is also attached. This "Notice" outlines the terms of the "Proposed Order". You may explain by way of representations to FRNSW why the Fire Safety Order – Order No.1 should not be given under Schedule 5, Part 7, Section 13 of the EP&A Act.

Representations are to be made in writing and should be received by FRNSW no later than **5.00 pm Thursday, 4 September 2025**. After hearing and considering any representations, under the provisions of Schedule 5, Part 7 (Section 14 and Section 15) of the EP&A Act, FRNSW may decide:

- to give a Fire Safety Order – Order No.1 in accordance with the "Proposed Order";
- to give a Fire Safety Order – Order No.1 in accordance with modifications made to the "Proposed Order";
- not to give a Fire Safety Order – Order No.1.

A copy of this "Notice" will be forwarded to City of Sydney Council, under the provisions of Schedule 5, Part 6 (Section 12) of the EP&A Act.

Fire and Rescue NSW	ABN 12 993 473 110	www.fire.nsw.gov.au
Community Safety Directorate Fire Safety Compliance Unit	1 Amartina Ave Greenacre NSW 2190	T (02) 9742 7434 F (02) 9742 7843
www.fire.nsw.gov.au		Page 1 of 5

OFFICIAL

OFFICIAL

OFFICIAL

OFFICIAL

Please do not hesitate to contact Inspector Paul Scott of FRNSW's Fire Safety Compliance Unit at FireSafety@fire.nsw.gov.au or call on (02) 9742 7434 if there are any questions or concerns about the above matters. Please ensure that you refer to file reference FRN25/1905 - BFS25/4178 - 8000043403 regarding any correspondence concerning this matter.

Yours faithfully



Paul Scott
Team Leader
Fire Safety Compliance Unit

C.C. Strata Manager
Ace Body Corporate Management North Shore

E-mail: northshore@acebodycorp.com.au

OFFICIAL

OFFICIAL



OFFICIAL

Proposed Fire Safety Order ORDER No. 1

*Under the Environmental Planning and Assessment Act 1979 (EP&A Act)
Part 9 Implementation and Enforcement – Division 9.3 Development Control Orders
Fire Safety Orders in accordance with the table to Part 2 - Schedule 5.
Intend to give an Order in accordance with Section 9.34(1)(b)*

I, **Paul Scott** **Inspector** **6776**
(name) (rank) (number)

being an authorised Fire Officer within the meaning of Schedule 5, Part 8, Section 16 of the *Environmental Planning and Assessment Act 1979*, and duly authorised for the purpose, hereby order:

THE OWNERS - STRATA PLAN NO. 77891 **Owner**
(name of the person whom Order is served) (position, i.e. owner, building manager)

with respect to the premise

48-50 STANLEY STREET DARLINGHURST ("the premises")
(name/address of premises to which Order is served)

to do or refrain from doing the following things:

1. Restore the fire hose reels to permit the withdrawal of the hose without fouling the hose reel drum.
2. Repair the fire brigade booster assembly cabinet doors so firefighters do not need to break the door to gain entry to utilise the fire hydrant booster.
3. Provide clearance around the sprinkler booster connection to facilitate the use of a hose spanner for the connection and disconnection of fire hose. The clearance required around the Storz coupling should be not less than 300 mm through an arc of 225° in the plane of the coupling (see example *Image 1*). This can be achieved by,
 - a. Providing hinged door access, or
 - b. Enlarging the opening in the timber surround.

Fire and Rescue NSW	ABN 12 593 473 110	www.fire.nsw.gov.au
Community Safety Directorate	1 Amarina Ave	T (02) 9742 7434
Fire Safety Compliance Unit	Greenacre NSW 2190	F (02) 9742 7943
www.fire.nsw.gov.au		Page 3 of 5

OFFICIAL

OFFICIAL

4. Secure the data and telephone cables in the hose reel and fire hydrant cabinets.

The terms of the Proposed Fire Safety Order – Order No.1 are to be complied with:

By no later than **30 days** from the date of the Fire Safety Order – Order 1.

The reasons for the issue of the Proposed Fire Safety Order - Order No.1 are:

- a. At the time of inspection, the building was occupied.
- b. Multiple hose reels were not rewound correctly which may cause the hose, when withdrawn, to fall over the back of the hose reel drum preventing its operation during first aid firefighting operations.
- c. FRNSW were unable to gain access to the fire hydrant booster assembly through the double door on Young Street. FRNSW were unable to determine if the keyed lock was broken or the cabinet doors were jammed.
- d. The fire hydrant system does not appear to incorporate an on-site pumpset. To undertake fire attack and search and rescue operations, firefighters are required to boost the system with a fire brigade pumping appliance.
- e. The timber recess (surround) of the sprinkler booster is not large enough to permit the connection of firefighting hose to boost the sprinkler system by a fire brigade pumping appliance. Less than a 5 mm gap was present around the Storz connection.
- f. The opening does not permit ease of operation of the equipment and may delay fire brigade boosting operations.
- g. Data and telephone cables were hanging loosely from the ceiling and lying on the floor of the fire hose reel and fire hydrant cabinets within the building. The cables may foul the fire hose reels or obstruct firefighters when connecting firefighting hose to the valved outlets.
- h. Australian Standard (AS) 2441-2005 – *Installation of Hose reels*, does not permit the installation of non-firefighting equipment within the cabinet.
- i. To do or refrain from doing such things specified in the Order to ensure or promote adequate fire safety or awareness.

Appeals

Pursuant to Section 8.18 of the Environmental Planning & Assessment Act 1979 (EP&A Act), there is no right of appeal to the Court against a Fire Safety Order – Order 1 once it is issued, other than an order that prevents a person from using or entering premises.

OFFICIAL

OFFICIAL

OFFICIAL

Non-Compliance with Fire Safety Order – Order No.1

Once issued, failure to comply with a Fire Safety Order – Order 1 may result in further Orders and/or fines being issued.

Substantial penalties may be imposed under Section 9.37 of the EP&A Act for failure to comply with a Fire Safety Order – Order No.1.

NOTE: Representations are to be made in writing and should be received by FRNSW no later than **5.00 pm on Thursday, 4 September 2025**.



Paul Scott
Team Leader
Fire Safety Compliance Unit

This **Proposed** Fire Safety Order - Order No. 1 was posted at the building and e-mailed on **21 August 2025**.

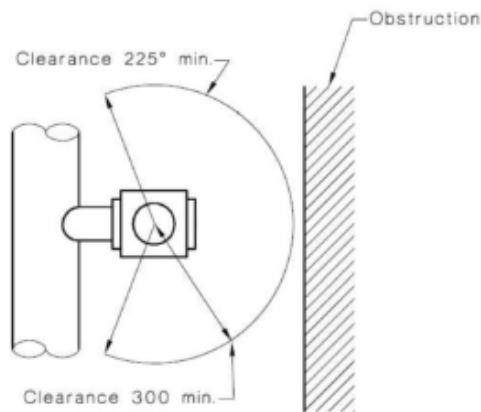

Figure 1 - Extract AS2419.1

OFFICIAL

OFFICIAL